



Mob-9438907686

ODISHA POWER TRANSMISSION CORPORATION LIMITED
OFFICE OF THE DEPUTY GENERAL MANAGER: ELECTRICAL
EHT (O&M) DIVISION, BHANJANAGAR,
AT: KANTEIPALLI, POST: BADAPADA, DIST: GANJAM (ODISHA), PIN: 761 124
E-mail - ehtm.div.bnj@optcl.co.in GSTIN: 21AAACO7873L1Z6

TENDER SPECIFICATION FOR NIT NO- 08/2017-18

FOR

**PROCUREMENT OF 4 NOS 415 V, 3 PHASE, 4 WIRE OUTDOOR ACDB CONSOLE BOX FOR GRID S/S
ASKA UNDER EHT (O&M) DIVISION, BHANJANAGAR**

ISSUED TO

.....

.....

COST OF TENDER PAPER = Rs. 2000/- + 12% GST = Rs. 2240/-



Mob-9438907686/9438907880

ODISHA POWER TRANSMISSION CORPORATION LIMITED
OFFICE OF THE DEPUTY GENERAL MANAGER:ELECTRICAL
EHT (O&M) DIVISION, BHANJANAGAR,
AT:KANTEIPALLI, POST:BADAPADA, DIST:ASKA(ODISHA), PIN: 761 124
E-mail - ehtm.div.bnj@ optcl.co.in GSTIN: 21AAACO7873L1Z6

TENDER CALL NOTICE No. 08/2017-18

For and on behalf of OPTCL, sealed tenders are invited by the undersigned from Manufacturers/Suppliers having valid IT PAN, GST Certificate (not registered in Composition Scheme) towards “**Procurement of 4 nos 415 V, 3 Phase, 4 wire Outdoor ACDB console box for Grid Sub-Station, Aska** under EHT (O&M) Division, Bhanjanagar.

Commencement of Sale of Tender Paper: - From Dated 13.02.2018, 11 AM to Dated 06.03.2018, 5:00 PM.

Last Date of Submission of Tender Paper: - Dated 06.03.2018 up to 2:00 PM.

Date of Opening of Tender Paper: - Dated 07.03.2018 at 3:00 PM.

Sl. No	Tender Specification No.	LOTS	Description of equipment/materials	Qty in Nos:	Earnest Money Deposit	Cost of Tender Spec. document (in Rs.)	Last date of receipt & opening of tender
1.	NIT NO-08 /2017-18, EHT (O&M) Division, Bhanjanagar	LOT-1	SUPPLY OF 415 V, 3 PHASE, 4 WIRE OUTDOOR ACDB CONSOLE BOX FOR 132 KV SWITCH YARD	02	Rs 1563/-	2,000/- + 12 % GST (Rs. 2,240/-	06-03-2018 (14.00 Hrs) & 07-03-2018 (15.00 Hrs)
2.		LOT-2	SUPPLY OF 415 V, 3 PHASE, 4 WIRE OUTDOOR ACDB CONSOLE BOX FOR 33 KV SWITCH YARD	02	Rs 1429/-		

N:B:- The Bidders can participate for one lot or both lots

The Tender specification can be obtained on payment of Rs. 2,000/- + GST@12%= Rs. 2,240/- in shape of Cash / Bank Draft drawn in favour of **EHT(O&M) Division, OPTCL, Bhanjanagar payable at Bhanjanagar** and an additional amount of Rs. 100/- (Rupees one hundred) only can be paid **well in advance** for postal delivery . The undersigned shall not be held responsible for any postal delay. The tender must be accompanied with requisite EMD in shape of Cash / Bank Draft drawn in favour of **EHT (O&M) Division OPTCL Bhanjanagar payable at Bhanjanagar**. Incomplete tender document and tender without EMD shall be rejected. If the last date of receipt/opening of Tender falls on a Holiday, then the tender paper will be received/ opened in the next working day. The undersigned reserves the right to accept or reject any or all tenders without assigning any reason thereof.

Sd/-

Dy. General Manager (Elect),
EHT (O&M) Division, Bhanjanagar

**TENDER SPECIFICATION OF NIT NO- 08/2017-18
OF EHT (O&M) DIVISION, BHANJANAGAR
FOR
PROCUREMENT OF 4 NOS 415 V, 3 PHASE, 4 WIRE OUTDOOR ACDB CONSOLE BOX FOR GRID S/S
ASKA**

CONTENTS

1. SECTION –I : INSTRUCTIONS TO BIDDERS.
2. SECTION –II : GENERAL TERMS & CONDITIONS OF CONTRACT.
3. SECTION –III : TECHNICAL SPECIFICATION & GENERAL TECHNICAL REQUIREMENTS.
4. SECTION –IV : ABSTRACT OF TERMS AND CONDITIONS
5. SECTION –V : PRICE BID.
6. SECTION –VI : NO RELATION CERTIFICATE

SECTION-I

INSTRUCTIONS TO BIDDERS

The bidders must read in detail the “Instructions to Bidders”, “General Terms and Conditions of Contract” and “Technical Specifications” before filling the Tender documents. There are six sections in this Tender Specification.

1. BIDDERS:

- A) Bidders must submit their bids with original signature. Only those who have purchased the Tender documents from this office can submit their Tender. Tenders submitted by other means will be rejected.
 - B) Tender must be submitted in sealed cover subscribed as “**Tender Call Notice No. 08/2017-18 towards SUPPLY OF 4 NOS 415 V, 3 Phase, 4 wire ACDB CONSOLE BOX GRID SUB-STATION ASKA under EHT (O&M) DIVISION, BHANJANAGAR**” on or before 28.02.2018 for opening and addressed to the Dy. General Manager, EHT (O & M) Division, Bhanjanagar.
 - C) Tender shall be submitted either in person or by registered post & any other means of delivery shall not be accepted. Detailed postal address with PIN No., Phone / Fax/Email of bidder must be mentioned in the application requesting for tender document and on the tender bid. The authority is not responsible for receipt of tender after due date due to postal delay or any other reasons. Tenders received after due date due to postal delay or any other reason will not be considered. The bidders who want to receive the tender paper by post have to deposit additional Rs. 100.00 along with the tender cost.
 - D) The tender must be accompanied by EMD in shape of Cash / Bank Draft drawn in favour of **EHT (O&M) Division, OPTCL Bhanjanagar payable at Bhanjanagar**. Those who claim exemption from furnishing the E.M.D should submit the requisite copy of documents on the basis of which, exemption is claimed. The EMD of successful Bidders will be refunded after deposit of security-cum-performance deposit. The EMD of all unsuccessful Bidders will be refunded on written request and after finalization of tender. No interest shall be paid on EMD. No adjustment towards EMD shall be permitted against outstanding amount, if any, remained with the OPTCL.
2. Experience: The Bidders should be registered order Suppliers/ Manufacturer. The bidders may submit the copy of past experience if any (**recent order copy to be furnished**) regarding supply of similar materials to GRIDCO/ OPTCL or any other state or central PSUs.

3. FORFEITURE OF EMD:

- A) In the event the successful Bidder fails to supply above ACDB console boxes as per the technical specification, the EMD so deposited shall be forfeited.
 - B) Any deviation from the terms and conditions of the contract the EMD so deposited shall be forfeited without any notice.
4. INFORMATION ON COMPETITORS: Bidders have right to know information on competitors only at the time of opening of the bids. No further information on competitors shall be provided at any other point / stage of the tender without prejudice to Right to Information Act – 2005.

5. OPENING OF TENDERS:

- A) Copy of PAN card/ GST Registration Certificate (**not registered in Composition Scheme**) must be enclosed with the tender bids.
 - B) Bidders themselves or their authorized representatives limited to one person only (possessing authorization letter in original) shall be allowed to attend opening event of the tenders.
6. The purchaser may alter the quantities of materials at the time of placing orders. Orders may also be split up among more than one bidders if necessary. The purchaser reserves the right to reject the lowest or any other Tender or all tenders without assigning any reason what so ever.
7. Tender should be prepared clearly and without any overwriting and corrections. Erasures and other changes shall bear the dated initial of the person signing the Tender.
8. In the event of discrepancy or arithmetical error in the schedule of price, the decision of the purchaser shall be final and binding on the Bidders. For evaluation, the price mentioned in words shall be taken if there is any difference in figure and word in the price bid.
9. **THE TENDERS SHALL BE LIABLE FOR REJECTION IF THEY DO NOT AGREE TO OR COMPLY WITH ANY OF THE TERMS AND CONDITIONS SET FORTH AND PROVIDED IN THE TENDER SPECIFICATION.**

SECTION-II
GENERAL TERMS AND CONDITIONS OF CONTRACT

1. **Scope of contract:** Materials shall be delivered at destination in accordance with the enclosed technical specification and quantity as per requirement (Section- III).
2. **Manner of execution:** All materials should be supplied under the contract shall confirm to the latest publication of relevant IS specification.
3. **Validity:** Bidders are requested to keep the validity of their offer for a period of 6 months from the date of opening of tender.
4. **Price:** The price quoted by Bidders should be firm, F.O.R. destination inclusive of freight, Insurance, Packing, Forwarding charges inclusive discount, if any.
5. **Taxes:** GST, if any shall be mentioned. The tender may quote rate in respect of different make materials as per scheduled.
6. **Terms of Payment:** 100% payment with GST etc. shall be made within 45 days after receipt of materials in good condition at stores/desired site, subject to prior approval of guarantee certificate by the Purchaser and verification thereof by the consignee.
7. **Delivery:** The materials in full quantity shall be delivered within 30 days of receipt of purchase order, failing which purchase order shall be liable for cancellation with forfeiture of Earnest money/ Security Deposit.
8. **Penalty:** If the supplier shall fail to deliver the materials within the delivery period as stipulated under clause No. 7 (Section-II) of this Tender document or any extension granted there to, the purchaser shall recover from the supplier penalty for a sum of half percent (i.e. 0.5 percent) of the contract price for each calendar week or part thereof of delay. However the total amount of penalty shall not exceed 5% (five percent) of the contract/ undelivered items price. Materials will be deemed to have been delivered only when all the component parts are also delivered. If certain components are not delivered in time, the supply will be treated as delayed until such time the missing/ undelivered parts are delivered period.
9. **Extension of time:** If the delivery of materials is delayed due to reason beyond the control of supplier, the supplier shall without delay give justification. The purchaser on receipt of such notice may agree to extend the contract delivery date if reasonable but without prejudice to other terms and conditions of this contract.
10. **Earnest Money Deposit:** The Bidders are requested to deposit EMD in shape of Cash/D.D. Drawn in favour of EHT (O&M) Division, OPTCL, Bhanjanagar payable at Bhanjanagar. The tender without EMD will be liable for rejection. The D.D / original money receipt for the EMD should be enclosed along with original tender paper.
11. **Security Deposit:** The Bidders whose offer qualifies for acceptance will be awarded Purchase Order and the supplier shall have to be deposit Security-cum-performance guarantee equal to 10% (Ten percent) of ordered value in shape of Cash / Bank Draft in favour of EHT (O&M) Division, OPTCL, Bhanjanagar. The Security deposit will be released after two months of completion of the guarantee period subject to fulfilment of guarantee stated under clause-12 on a receipt of application for this purpose. No interest shall be paid to the supplier towards the security deposit so deposited by the supplier.
12. **Guarantee:** The materials covered under this contract should be guaranteed for trouble free and satisfactory performance against any defect in design, materials and workmanship for a Period of at least 18 (Eighteen) months from the date of delivery or 12 (twelve) months from the date of commissioning, whichever is earlier. Any defect noticed during this period should be rectified / replaced by the firm free of cost provided such defects are due to faulty design, bad workmanship or bad materials used. The replaced materials should also have similar guarantee. In the event of any breach on default in all or any condition of purchase order Security Deposit will be forfeited.
13. **Insurance:** Insurance of materials is to be done by the supplier at their own cost. The responsibility of delivery of the materials at destination in good condition rests with the supplier. Any claim with the insurance company Railway authority/ Road transport authorities arises due to loss or damage in transits has to be settled by the supplier. The supplier shall undertake free replacement of materials damage or lost which will be reported by the consignee within 30 Days of the receipt of the materials at destination without waiting for the settlement of the claims with the carriers.

14. **Despatch Instruction:** The materials should be securely packed and dispatched by Rail/ road transport to Grid Sub-Station Aska. The cost of transportation will be borne by the supplier.
15. **Consignee:** The SDO, Grid Sub-Station, Aska is the consignee & verifying officer for the contract.
16. **Paying Officer:** The DGM, EHT (O&M) Division, Bhanjanagar is the paying officer for this contract.
17. **Submission of PAN & GST Registration Certificate:** Clear attested Xerox copies of PAN issued by the competent authority & GST Registration Certificate (**not registered in Composition Scheme**) on or before the date of opening of tender should be submitted along with the tender, failing which the tender will be rejected. The supplier may be requested to produce original PAN card & VAT Clearance certificate at the time of opening of the tender. Those who fail to produce the same & found not to be valid on the date of opening the tender, their tender should be rejected.
18. **Past Experience of supply:** The bidders should submit past experiences (i.e. **recent order copies to be furnished**) at least one supply experience should be from OPTCL or any other state or central PSUs regarding supply of similar type of AC/DC console box (Indoor/Outdoor).
19. **Jurisdiction of Court:**

Dispute if any, arising against the supply order issued to the supplier shall be filed by either party in any court of law to which the jurisdiction of Odisha High Court extends.

The Authority reserves the right to reject the notice/ award the contract among any responsive bidders against this tender or without assigning any reason thereof. All other terms and conditions will be governed by OPTCL as per Rules.

All other terms and conditions will be governed by OPTCL as per Rules.

SECTION-III

TECHNICAL SPECIFICATION & GENERAL TECHNICAL REQUIREMENTS.

For 132 KV & 33 KV ACDB console Boxes (Outdoor Type)

- 1. ACDB** shall be fabricated with 1.6 mm CR sheet steel, dust & Vermin proof duly painted with powder coated Siemens grey colour with two nos. of 40 x 40 x 5 mm MS angle welded at the bottom. The boxes should conform to IP-55 degree of protection.
- 2. Panel** must have both front and rear doors (hinged, gaskets & manual locking arrangement to be provided) with two nos. of Eye bolt on top for lifting the panel.
- 3. Roof** of the panel to be slightly slanting i.e. minimum 50 mm out from panel. Copper strip (25 x 5 mm) to be provided as earth bus bar with extension of minimum 50 mm from the panel.
- 4. DOOR switch** along with batten holder to be provided on the panel. The bus bar (Copper) should not be less than 25 x 5 mm, to be mounted on DMC insulator and to be covered with heat shrinkable PVC colour sleeves i.e. Red, Yellow, Blue & Black for neutral.
- 5. GENERAL drawing & single line diagram** as stipulated in the technical specification should be followed strictly for perfection of complete of wiring.
- 6. Console** box should have provision for adequate intensity of lighting inside i.e. 9 Watt LED lamps.
- 7. Bus bars** shall be conveniently placed so as to provide adequate clearance between phases, phases to ground and from the body of the box conforming to I.E. Rules applicable for LT supply. The bus and connections shall be so supported as to be capable of safety withstanding stresses due to maximum short circuit current and also take care of any thermal expansion.
- 8. WIRING** shall be complete in all respect with supply of wires. All wiring shall be complete up to the terminal blocks. Each wire shall be identified at both ends with wire destinations numbered ferrules in accordance with wiring diagram. Wires shall not be spliced or tapped between terminal points. Each wire shall be continuous and there shall not be any jointing within it. Wires shall be neatly bunched inside the cable duct. The wiring shall be of 1.1 KV grade. Terminals should be so mounted that the appropriate wire may be connected without impair the normal performance of the unit.
- 9. Suitable cable** glands of heavy duty, double compression type made up of Brass shall be provided at the bottom of the Box. (2 nos for two 35 mm², 3 ^{1/2} core incoming cable, 12 nos of 2.5 mm² 4 core outgoing cables for 132 KV console box and 15 nos of 2.5 mm² 4 core outgoing cables for 33 KV console box). Two pieces detachable plates at the bottom shall be provided for fixing of cable glands
- 10. MCCB** shall be of reputed make M/s L&T, M/s Siemens, M/s Schneider, or M/s ABB with Over Current Setting 80% to 100% for Incomer shall confirm to IS – 13947 (pt – 2)/1993 with latest amendment. 35 mm², 3 ^{1/2} core cable.
- 11. COMPLETENESS** of equipment: - Any fittings accessories or apparatus which may not have been specifically mentioned in this specification but which are usually necessary in equipment of similar plant shall be deemed to be included and shall be supplied by the Bidder without extra charge. All plant and equipment shall be complete in all details whether such details are mentioned in the specification or not.

THE 132 KV CONSOLE BOX SHOULD COMPLY WITH FOLLOWING MATERIAL:

Sl. No.	DESCRIPTION
1	63A TPN MCB-1 no
2	16A TP MCB-6 nos
3	10A DP MCB-6 nos
4	Bus bar Insulator-11 nos or as appropriate
5	Bus bar Sleeves- as appropriate
6	Socket with wiring at 24 points or as appropriate
7	Door hinges with Lock and key- as appropriate
8	Door gasket- as appropriate
9	Din Rail- as appropriate
10	HRC fuse base with carrier (20 A, 550V AC)- 200 nos
11	HRC fuse, 6A-120 nos
12	Neutral links with Base and carrier, 15A-200 nos
13	Terminal Blocks (CAT-M4)-90 nos
14	Terminal Blocks (CAT-10)-8 nos
15	Cable Duct-7 meters approx or as appropriate
16	Base Angle (40 x 40 x 5 mm) for mounting

THE 33 KV CONSOLE BOX SHOULD COMPLY WITH FOLLOWING MATERIAL:

SI No.	DESCRIPTION
1	63A TPN MCB-1 no
2	16A TP MCB- 6 nos
3	Bus bar Insulator-12 nos or as appropriate
4	Bus bar Sleeves- as appropriate
5	Socket with wiring at 24 points or as appropriate
6	Door hinges with Lock and key- as appropriate
7	Door gasket- as appropriate
8	Din Rail- as appropriate
9	HRC fuse base with carrier (20 A, 550V AC)- 200 nos
10	HRC fuse, 6A-120 nos
11	Neutral links with Base and carrier, 15A-200 nos
12	Terminal Blocks (CAT-M4)-80 nos
13	Terminal Blocks (CAT-10)-8 nos
14	Cable Duct-7 meters approx or as appropriate
15	Base Angle (40 x 40 x 5 mm) for mounting

**N:B- All wirings to be made of 16 Amp -4 sq.mm PVC copper flexible wire with supply of wire.
All Fuses should be mounted with screw instead of DIN rail.**

GENERAL ARRANGEMENT DRAWING OF ACDB FOR 132 KV SWITCHYARD

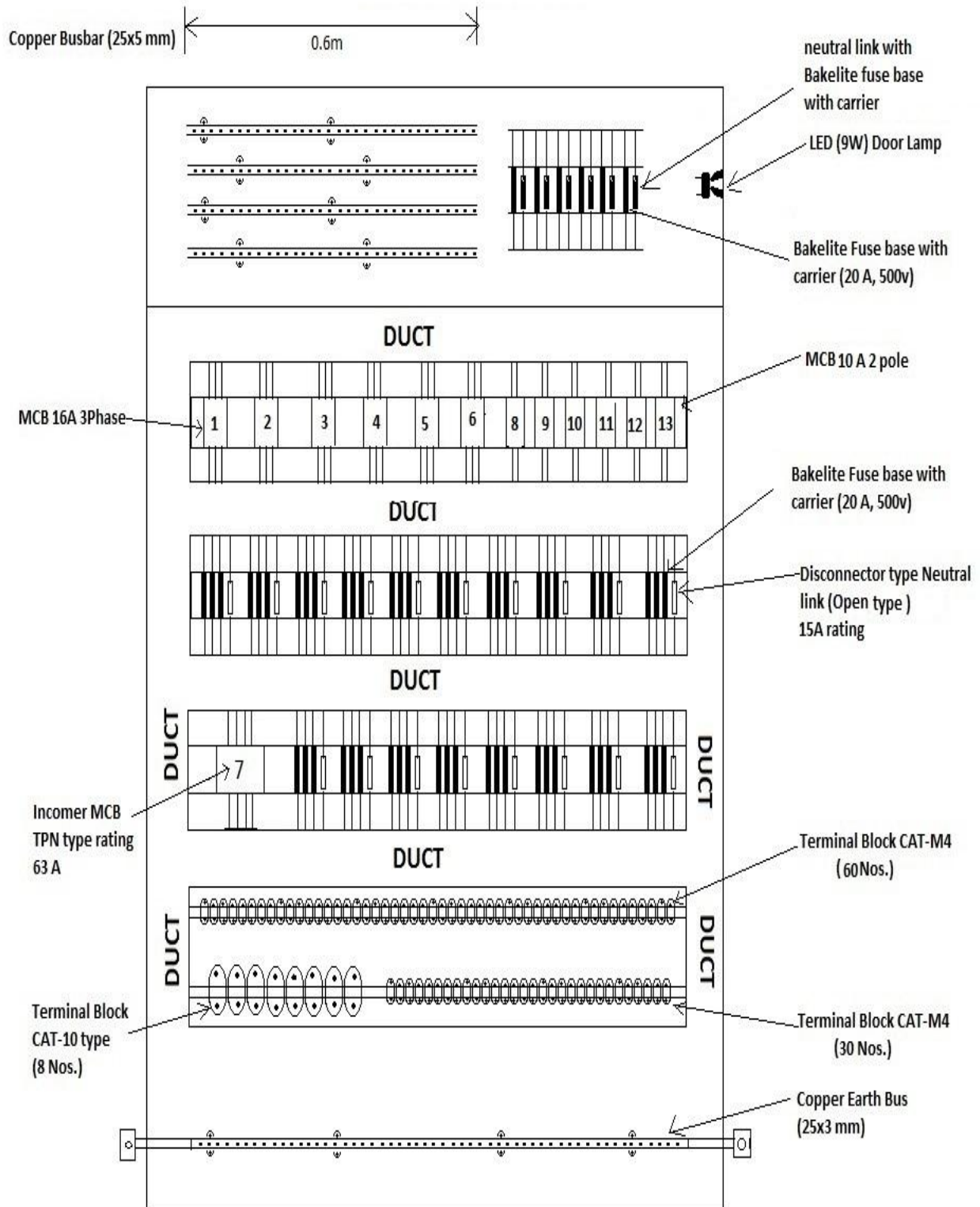

NB :
 MCB (1-6) :- 16A 3Pole
 MCB 7 :- 63A 4 Pole
 MCB (8-13) :- 10 A 2Pole

SINGLE LINE DIAGRAM OF ACDB PANEL FOR 132 KV SWITCHYARD

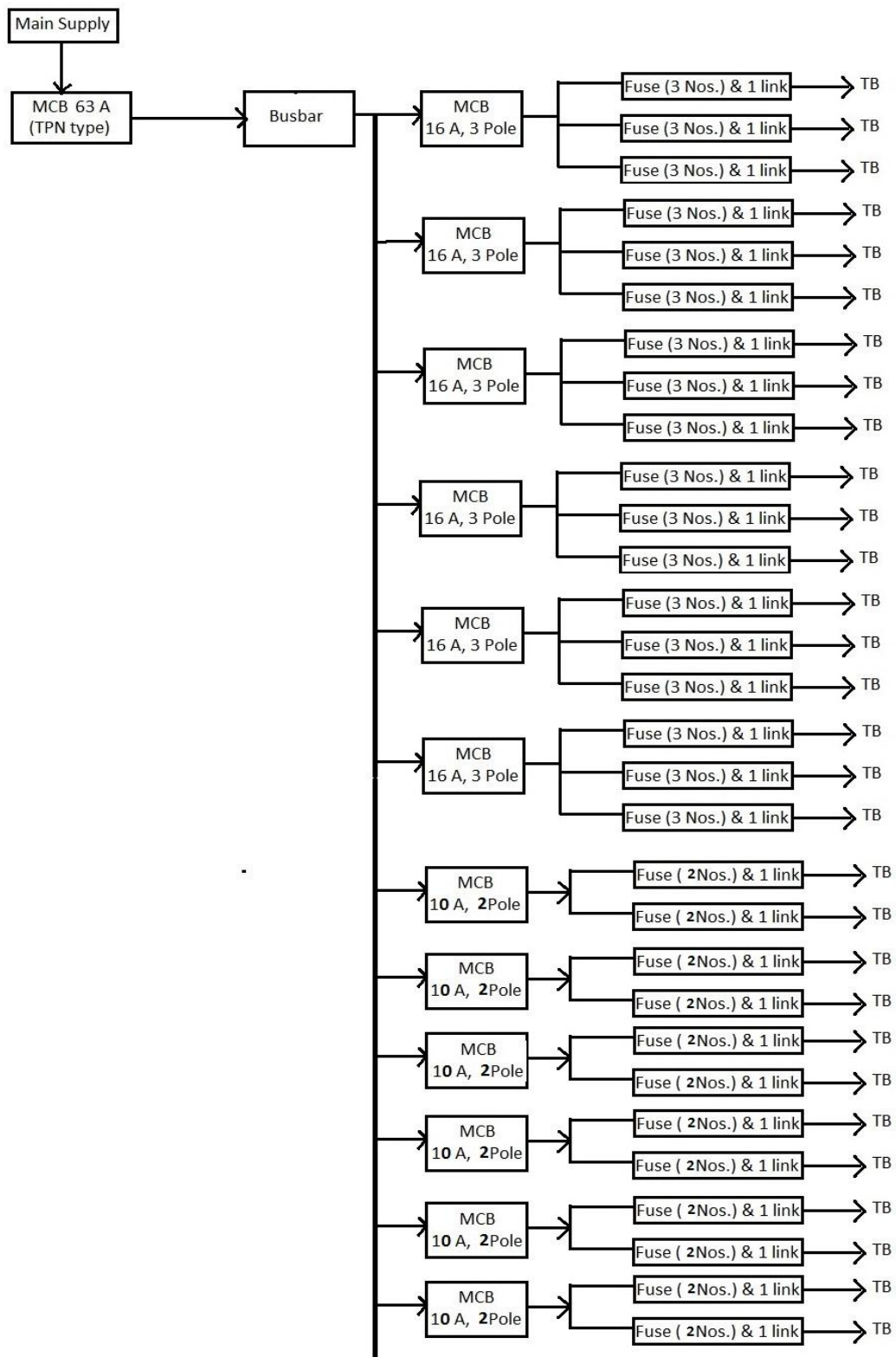

GENERAL ARRANGEMENT DRAWING OF ACDB FOR 33 KV SWITCHYARD

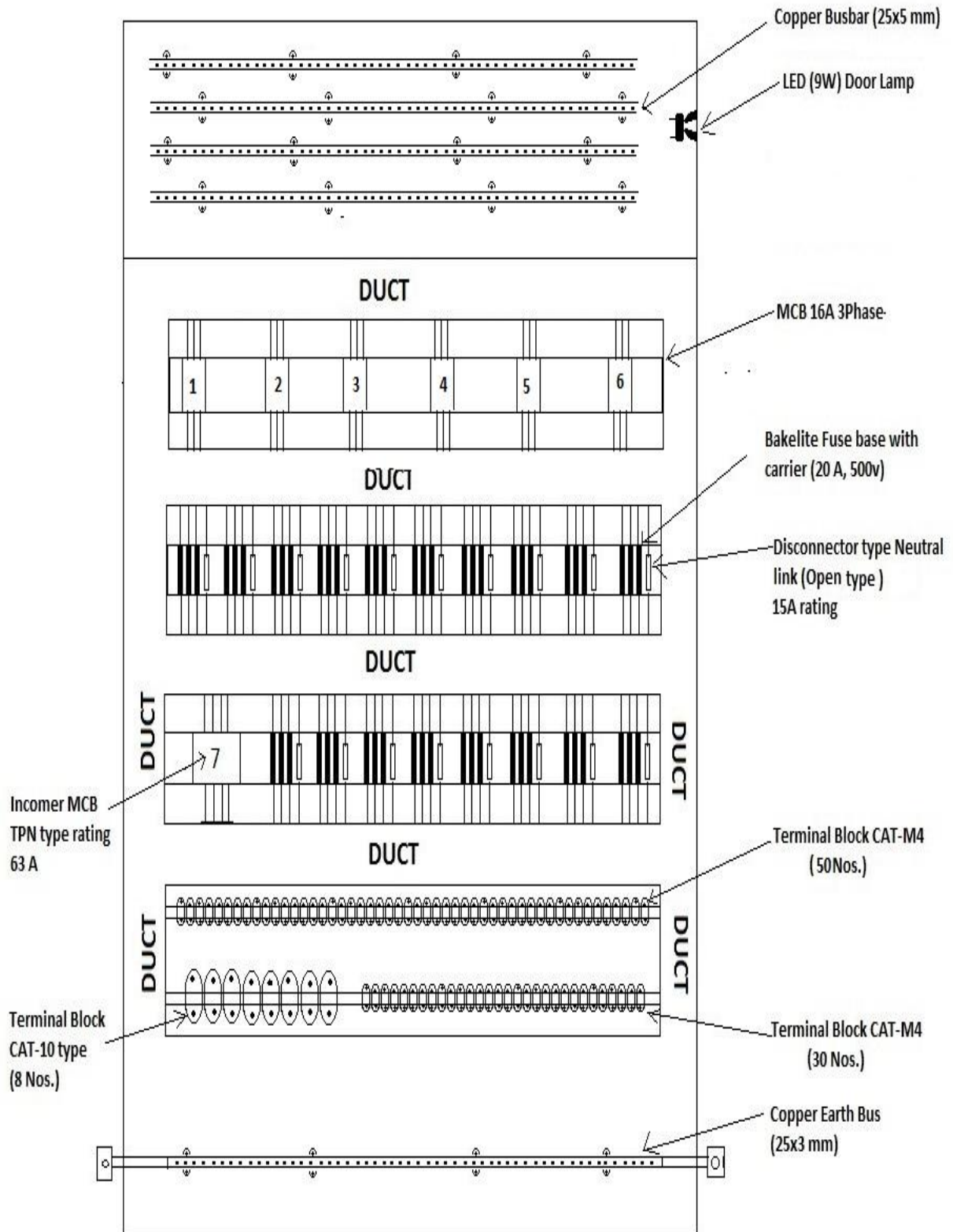

NB :
 MCB (1-6) :- 16A 3Pole
 MCB 7 :- 63A 4 Pole

SINGLE LINE DIAGRAM OF ACDB PANEL FOR 33 KV SWITCHYARD

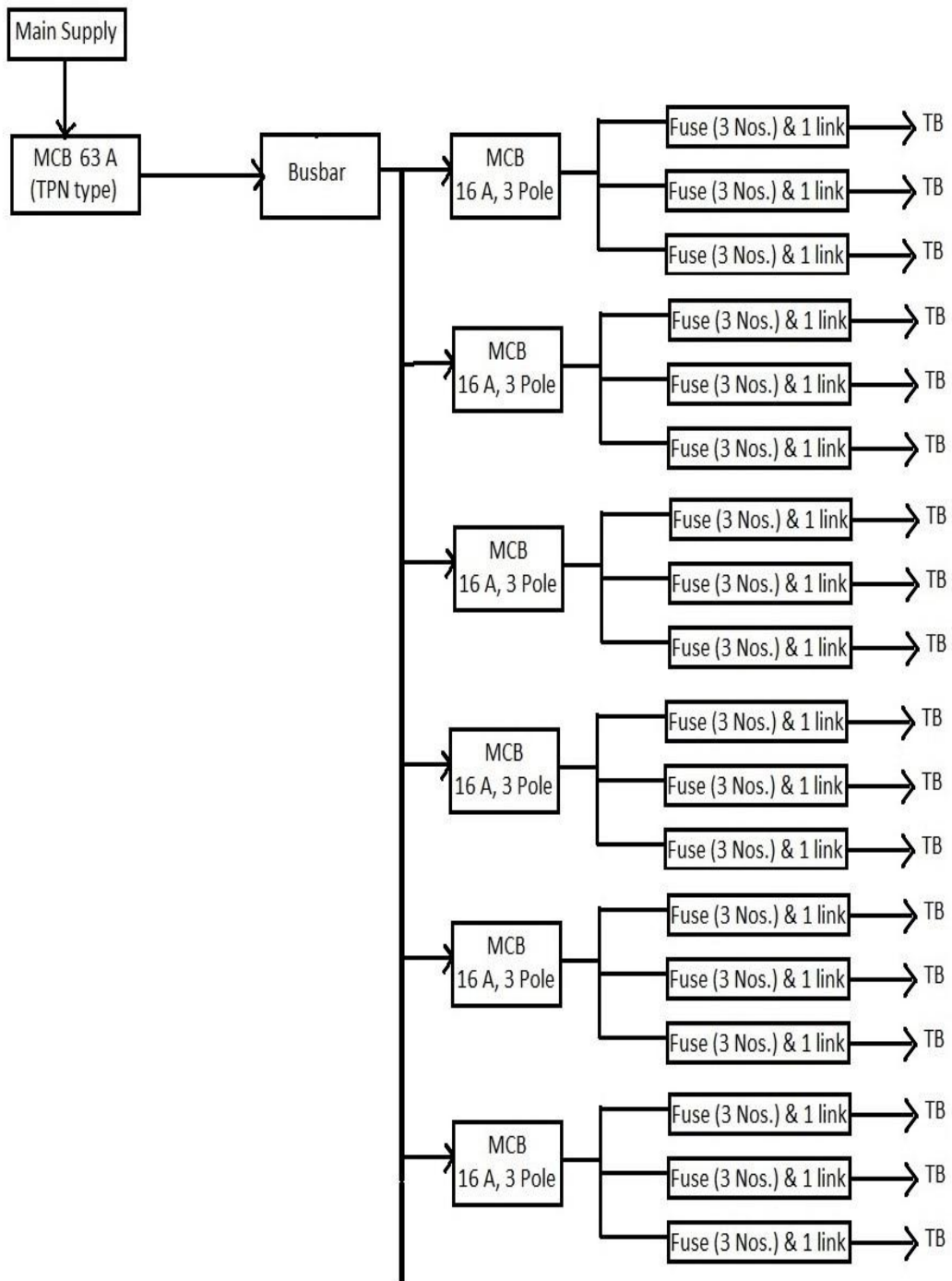

SECTION-IV

ABSTRACT OF TERMS AND CONDITIONS

(This Proforma should be filled with all information and should be furnished along with the tender)

1	Earnest Money Deposit(EMD) deposited in shape of Cash/Bank Draft	Yes/No
a	Name of the Bank(For Bank Draft): (To be furnished)	
b	Amount deposited: (To be furnished)	
c	Money Receipt No. & Date / Bank Draft No. & Date: (To be furnished)	
2	Validity of the bid in days from the date of opening of tender (As per Specification): (To be furnished)	
3	Nature of Price:	Firm/Variable
4	Terms of payment (Whether agreeable to OPTCL terms:	Yes/No
5	Security deposit (Whether agreeable to OPTCL terms):	Yes/No
6	Penalty (Whether agreeable to OPTCL terms):	Yes/No
7	List of orders executed/or in hand for similar work during recent three years in OSEB/OPTCL/any PSU:	Yes/No
8	Copy of PAN furnished:	Yes/No
9	Copy of GST Registration (not registered in Composition Scheme) Certificate furnished:	Yes/No
10	Guarantee (Whether agreeable to OPTCL terms):	Yes/No
11	Delivery period (Whether agreeable to OPTCL terms):	Yes/No
12	No relation certificate (Furnished)	Yes/No
13	Agreed to all terms and conditions of the tender specification:	Yes/No

Signature of Bidders with Seal

SECTION-V

PRICE BID FOR NIT- No- 08/2017-18

Sl. No.	Description of materials to be supplied	Qty in nos.	Unit Rate in Rs.	Amount in Rs.
1	SUPPLY OF 415 V, 3 PHASE, 4 WIRE OUTDOOR ACDB CONSOLE BOX FOR 132 KV SWITCH YARD	02		
2	SUPPLY OF 415 V, 3 PHASE, 4 WIRE OUTDOOR ACDB CONSOLE BOX FOR 33 KV SWITCH YARD	02		
3	Total			
4	Taxes if any (to be specified) @			
5	Grand Total (Sl. No. 3 to 4) in Rs.			
6	Grand Total (Sl. No. 3 to 4) in figure			

- The Unit Rate should be inclusive of Packing, Forwarding, Transportation and cost of Insurance, Tax as specified in Sl. 4 i.e., GST
- The evaluation will be done as per statutory applicable taxes

Date:

Signature of the Bidders with Seal

Place:

SECTION – VI

NO RELATION CERTIFICATE

THIS IS TO CERTIFY THAT I / WE HAVE NO RELATIONSHIP WITH ANY OF THE EMPLOYEES IN THE RANK OF ASST. MANAGER AND ABOVE SERVING UNDER OPTCL, ODISHA. IN CASE THE ABOVE STATEMENT IS FOUND TO BE FALSE, I / WE MAY BE DEBARRED FROM ANY PAYMENT DUE ON ACCOUNT OF THIS CONTRACT.

SIGNATURE OF THE BIDDERS

END OF TENDER SPECIFICATION